



Owner Instructions

Original instructions

Warning! Read instructions before using the machine



TT 4045
TT 4055

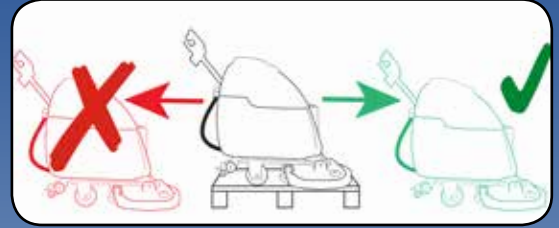

TT 4055



TT 4045



www.numatic.com





Index	Page 2
Machine overview	Page 3
Rating label / Personal Protective Equipment / Recycling	Page 4
Safety Precautions / Specifications	Page 5 / 6

Machine Set Up

Tilting the Handle	Page 6
Fitting the Top Tank	Page 6
Fitting the Brush	Page 7
Tipping the Brush Deck	Page 7
Fitting the Floor-tool	Page 7
Fitting the hose guide	Page 8
Fill the Clean-water tank	Page 8
Clean Water Level	Page 9
Control of Cleaning substances (COSHH)	Page 9
Clean Water Tap On / Off	Page 9
Pre Cleaning	Page 9
Pre Scrubbing	Page 10
Lowering the floor-tool	Page 10
Breakaway floor-tool feature	Page 10
Setting the cleaning controls	Page 11

Regular Maintenance

Tanks and Filters	Page 12
Changing the Floor-tool Blades	Page 13
Specifications	Page 14
Trouble shooting	Page 15
Recommended spare parts	Page 15
Schematic Diagram	Page 16
Warranty	Page 18
Declaration document	Page 19
Company Addresses	Page 20

Machine Overview



1	Operator Control Panel	12	On / Off Switch
2	Separator	13	Triggers
3	Top Tank (waste-water)	14	Clean-water Tank Fill Point / Filler Hose
4	Waste-water Emptying Hose	15	Floor-tool Vacuum Hose
5	Bottom Tank (clean-water)	16	Vacuum Hose
6	Deck Locking Pin	17	Clean-water Tank Emptying Hose & Fill Level
7	Brush Deck	18	Floor-tool Lifting Lever
8	Handle Position Lever	19	Floor-tool Retaining Knobs
9	Vacuum Switch	20	Semi Parabolic Floor-tool
10	Pump Switch	21	Clean Water Filter
11	Power Light	22	Brush

About the Machine

Rating Label

- 1 Company Name & Address
- 2 Machine Description
- 3 Voltage Frequency
- 4 Power rating
- 5 Max Gradient
- 6 Weight (ready to use)
- 7 CE Mark
- 8 WEEE Logo
- 9 Ingress Protection Rating
- 10 Machine Year/Week Serial number

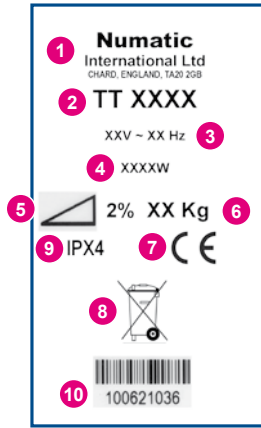

- 11 Machine Description
- 12 Noise Rating
- 13 Hand Arm Vibration

WEEE (Waste, Electrical and Electronic Equipment)

Scrubber dryer Accessories and packaging should be sorted for environmentally-friendly recycling. **Only for EU countries.**

Do not dispose of scrubber-dryer into household waste.

According to the European Directive 2002/96/EC on waste electrical electronic equipment and its incorporation into national law.

Scrubber-dryers that are no longer suitable for use must be separated, collected and sent for recovery in an environmentally-friendly manner.

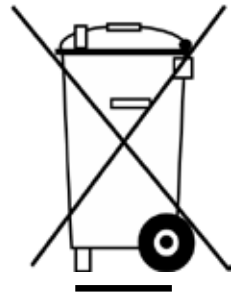

PPE (Personal protective equipment) that may be required for certain operations.

Ear Protection	Safety Footwear	Head Protection	Safety Gloves	
Dust/Allergens Protection	Eye Protection	Protective Clothing	Hi-Vis Jacket	
				Caution Wet Floor Sign

Note:

A risk assessment should be conducted to determine which PPE should be worn.

Safety Critical Component:

Mains lead:

H05VV-F x 1.5 mm² x 3 core

In the event of a breakdown contact your Numatic dealer or the Numatic Technical help line +44 (0)1460 269268

Information for Scrubber Dryer



**ORIGINAL INSTRUCTIONS
READ MANUAL BEFORE USE**

Component	Interval	Inspect for
Mains Lead	DAILY	Scuffing, cracks, splits, conductors showing
Brushes	DAILY	Bristle damage, wear, drive collar wear
Squeegee Blade	BEFORE EACH USE	Wear, cracks, splits
Filters	BEFORE EACH USE	Clogging and debris retention
Tanks	AFTER EACH USE	Rinse dirty water tank after use



WARNING

As with all electrical equipment care and attention must be exercised at all times during its use, in addition to ensuring that routine and preventative maintenance is carried out periodically in order to ensure its safe operation.

Failure to carry out maintenance as necessary, including the replacement of parts to the correct standard could render this equipment unsafe and the manufacturer can accept no responsibility or liability in this respect.

When ordering spare parts always quote the Model Number / Serial Number specified on the Rating Plate.

This appliance is not intended for use by persons (including children) with reduced physical, sensory or mental capabilities, or lack of experience and knowledge, unless they have been given supervision or instruction concerning use of the appliance by a person responsible for their safety.

Children should be supervised to ensure that they do not play with the appliance.



CAUTION

This machine is not suitable for picking-up hazardous dust.

Do not use on surfaces having a gradient exceeding that marked on the appliance.

The machine is not to be stored outdoors in wet conditions.

This machine is for indoor use only.

Read the instruction manual before using the appliance.

This product meets the requirements of IEC 60335-2-72

NOTES

This machine is also suitable for commercial use, for example in hotels, schools, hospitals, factories, shops and offices for other than normal housekeeping purposes.



DO

- Ensure only competent persons unpack/assemble the machine.
- Keep your machine clean.
- Keep your brushes in good condition.
- Replace any worn or damaged parts immediately.
- Regularly examine the power cord for damage, such as cracking or ageing. If damage is found, replace the cord before further use.
- Only replace the power cord with the correct Numatic approved replacement parts.
- Ensure that the work area is clear of obstructions and / or people.
- Ensure that the working area is well illuminated.
- Pre-sweep the area to be cleaned.



DON'T

- Use steam cleaners or pressure washers to clean the machine or use in the rain.
- Attempt machine maintenance or cleaning unless the power plug has been removed from the supply outlet.
- Allow any inexperienced repairs. Call the experts.
- Strain cable or try to unplug by pulling on cable.
- Leave the brush pad on the machine when not in use.
- Allow the machine to be used by inexperienced or unauthorised operators or without appropriate training.
- Use the machine without the solution tanks properly positioned on the machine, as shown in the instructions.
- Expect the machine to provide trouble-free, reliable operation unless maintained correctly.
- Lift or pull the machine by any of the operating triggers, use the main handle.
- Remove the handle from the machine except for service and repair.
- Use on surfaces having a gradient exceeding that marked on the machine.



- Only use brushes provided with the appliance or those specified in the instruction manual.
- The use of other brushes may impair safety.
- A full range of brushes and accessories are available for this product.
- Only use brushes or pads which are suitable for the correct operation of the machine for the specific task being performed.
- It is essential that this equipment is correctly assembled and operated in accordance with current safety regulations.

- When using the equipment always ensure that all necessary precautions are taken to guarantee the safety of the operator and any other persons who may be affected.
- Wear nonslip footwear when scrubbing. Use a respiratory mask in dusty environments.
- The machine, while charging, must be positioned so that the mains plug is easily accessible.
- When cleaning, servicing or maintaining the machine, replacing parts or converting to another function the power source shall be switched off.
- Mains operated machines shall be disconnected by removing the power plug, and battery operated machines shall be disconnected by switching off the isolating key.
- Machines left unattended shall be secured against unintentional movement.
- When detergents or other liquids are used, read the manufacturer's instructions.
- Do not allow the supply cord to come into contact with the rotating brushes.
- Operators shall be adequately instructed as to the correct use of the machine.

Machine Set Up



PLEASE READ BEFORE COMMENCING ANY OPERATION
AFTER THE REMOVAL OF ALL THE PACKAGING, CAREFULLY OPEN AND CHECK THE CONTENTS



Tilting the handle



Using the handle position lever (Fig.1).

Move the handle into the upright position (Fig.2).



Fitting top tank



Fit the top tank to the machine (Fig.3).

Fit both **vacuum** and floor-tool hose to the separator (Fig.4).



Fitting the brush

Featuring the Nulock brush system.

The brush is simply pushed and twisted to lock, making fitting and removal a simple process.

The Pad is retained using Numatic's own PadLoc system (ask your supplier for details).

Only use manufacturer supplied brushes / pads.

TT 4045 requires a 450mm brush or a 400mm pad.

TT 4055 requires a 550mm brush or a 500mm pad.



Fit the brush / pad to the drive chuck, twist to lock the brush (Fig.5) / pad in place (Fig.6).



Safety gloves are recommended for the changing of used brushes.

Tipping the Brush Deck



To tip the deck into the down position (Operating mode). Press in the brush deck locking pin (Fig.7) and rotate the brush deck (Fig.8).



To change to brush deck up position, (Transit mode) simply lift the deck and the sprung loaded locking pin will activate to hold the deck up.



ALWAYS ENSURE THAT THE MACHINE IS SWITCHED OFF BEFORE MAKING ANY ADJUSTMENTS



Fitting the Floor-tool

The floor-tool has been designed for quick fitting, allowing easy squeegee blade replacement and a safety knock-off feature if the floor-tool gets snagged, whilst in transit.

Note:

It is easier to fit the floor-tool if the weight of the machine is resting on the brush. Ensure the brush is fitted first.



Fit the floor-tool and retain using the detent pin (Fig.9).

The lifting strap is held by a detent pin (Fig.10).



Raise the floor-tool for transit or lower for cleaning operation using the lifting handle fitted to the back of the machine (Fig.11).

For fitting the floor-tool blades (See Page 13).

Machine Set-Up

Fitting the Hose Guide

The vacuum hose has a U-bend clip which creates a U-bend in the hose preventing water spillage when the vacuum is switched off. If you need to remove the U-bend clip for any reason always ensure it is refitted correctly before you resume operation (Fig 36-39).



Refit vacuum hose to the Floor-tool when finished.

Note:
DO NOT push the vacuum hose onto the Floor-tool with the Floor-tool in the raised position.

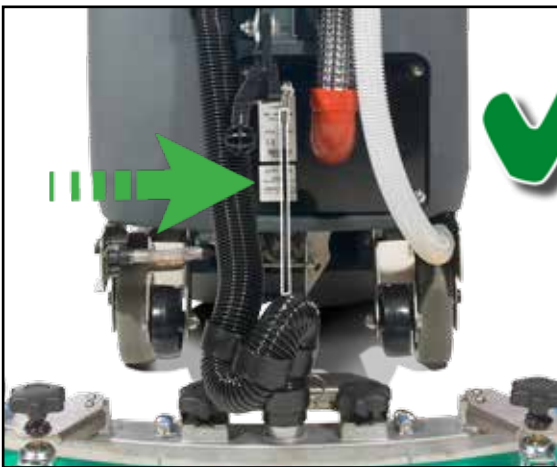

Note:
Raise floor-tool again before driving to the cleaning area.

Filling the clean-water tank

The TT Range are all equipped with a 40 litre clean-water tank allowing large areas to be cleaning in a single fill. To fill the clean-water tank, use the FLEXI - FILL pipe from either a tap or hose pipe (Fig.12).



The large cap on the left can be removed for filling from a bucket or suitable container (Fig.13).

Fill the clean-water tank to a maximum of 40 litres, including cleaning chemicals if required. Follow chemical manufactures guide lines.



Note:
Great care must be taken to ensure that contaminants (leaves, hair, dirt, etc) are not allowed to enter the clean-water tank during the filling process. If using a bucket or similar, ensure it is always clean and free from debris.

Machine Set-Up

Clean water level

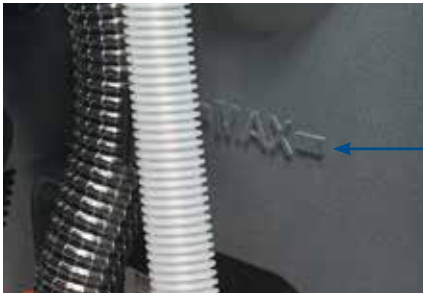

The water level in the clean-water tank can be seen using the clean-water clear dump hose fitted to the rear of the machine.

MAX

The clean-water bottom tank holds 40 litres.



Control of Substances Hazardous to Health (COSHH)

For best results use a non-foaming type of chemical, dilute to the manufacturer's specification.

For further guidance on hazardous substances refer to health and safety instructions online.

Visit <http://www.hse.gov.uk/> for UK information.



WHEN HANDLING AND MIXING CHEMICALS

*Always ensure that chemical manufacturer's safety guidelines are followed.
Only use chemicals recommended for use in auto scrubber-dryers.*



IMPORTANT

Do not operate machine unless the Operator Manual has been read and fully understood.



Clean water tap



Turn on the clean-water tap.

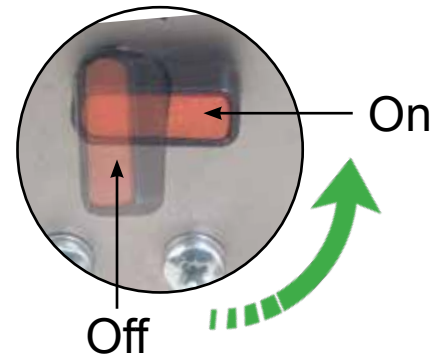

Machine Operation

14



Pre-cleaning advice

Before performing the cleaning operation, place out appropriate warning signs and sweep or dust-mop the floor (Fig.14).

*Numatic part (629044) Wet Floor sign
(available if required)*



**ALWAYS ENSURE THAT THE FLOOR IS PRE-SWEPT
AND RELEVANT SAFETY SIGNS ARE DISPLAYED**



Pre-scrub mode

The TT Range have been designed to cope with a variety of floor types and different levels of soiling.

On heavily soiled floors use a 'double scrub' technique.

First pre-scrub the floor with the floor-tool in the raised position, allow the chemical time to work, then scrub the area a second time with the floor-tool lowered.

Floor-tool in use

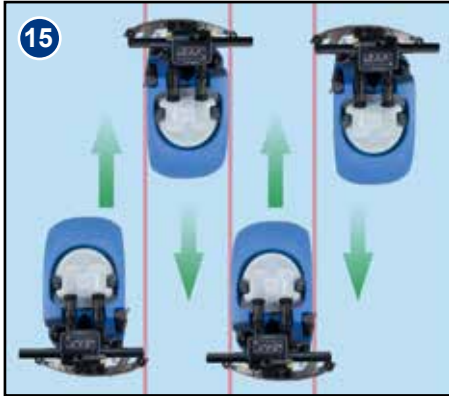

The clean-water / chemical mix is dispersed via the 'THRU-FEED' system.

The waste water is then retrieved by the floor-tool.

Overlap the scrubbing path by 10cm to ensure an even clean (Fig.15).

If streaking occurs, wipe the floor-tool blades clean (Fig.16).



Lowering the floor-tool



After preparing the floor (see previous section), we are now ready to set the controls to suit the cleaning conditions.

Before any settings can be applied, ensure the brush deck is lowered.

Move the floor-tool lever (see Fig.17), to it's lower position (see Fig.18).



Note: The machine will still reverse with the floor-tool in the lowered position, this could possibly damage the blades. Raise the floor-tool before reversing.



Breakaway floor-tool

The floor-tool design incorporates a safety knock-off feature.

Allowing it to safely disengage from its mounting should it become caught on an obstruction, during forward machine movement.

To re-attach the floor-tool blade to its holder, first loosen the retaining knobs on the floor-tool body and slide onto the holding bracket.

Tighten retaining knobs to finger tight (See Fig.19).

Note: Care must be taken to reduce speed when cornering or when manoeuvring around obstacles.

Setting the cleaning controls



Ensure your TT machine has been plugged into a suitable power supply.

Select the desired function using the on / off switches fitted to the handle.

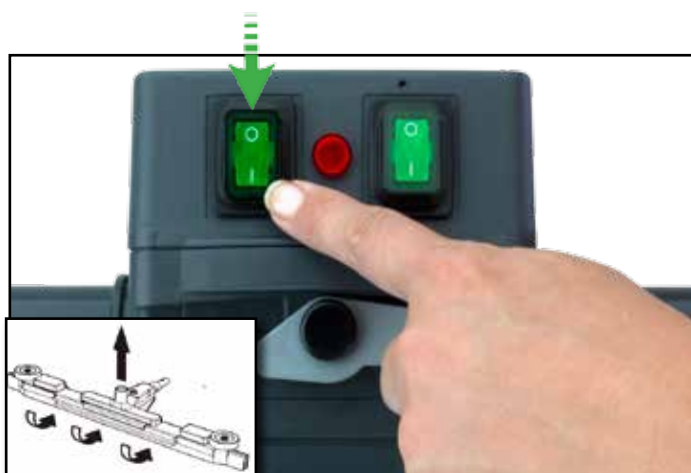

To start: hold down either trigger and press the yellow On / Off Switch once



Regular Maintenance



**ALWAYS ENSURE THAT THE BATTERY IS DISCONNECTED
PRIOR TO ANY MAINTENANCE OPERATION**



The TT Range has been designed with ease of use in mind, this included easy stripping-down and cleaning. After use, empty waste-water tank using emptying hose and flush out with clean-water (Fig.20).



Remove the two hoses to disconnect the separator from the machine (Fig.21).

Lift off the separator. The separator has a sealing-rubber which should be examined at every clean-down (Fig.22).

Rinse using clean-water.



Remove the filter fitted into the separator and flush with clean-water (Fig.23) (Fig.24).

Placed into the top tank is grey filter basket, clean and flush with clean-water (Fig.25) (Fig.26).



The bottom (clean-water) tank is attached to the chassis and should only be removed by a competent service engineer (Fig.27).

Clean by flushing with clean-water if required.

Excess water can be drained using the clear dump hose fitted to the rear of the machine.

Located under the left hand side is a clean-water filter, ensure the clean water tap is turned off before removing this filter (Fig.28).

Clean and flush with clean-water if required.



Changing the Floor Tool Blades



**ALWAYS ENSURE THAT THE BATTERY IS DISCONNECTED
PRIOR TO ANY MAINTENANCE**



The floor-tool

The TT range is provided with the aluminium floor-tool shown.

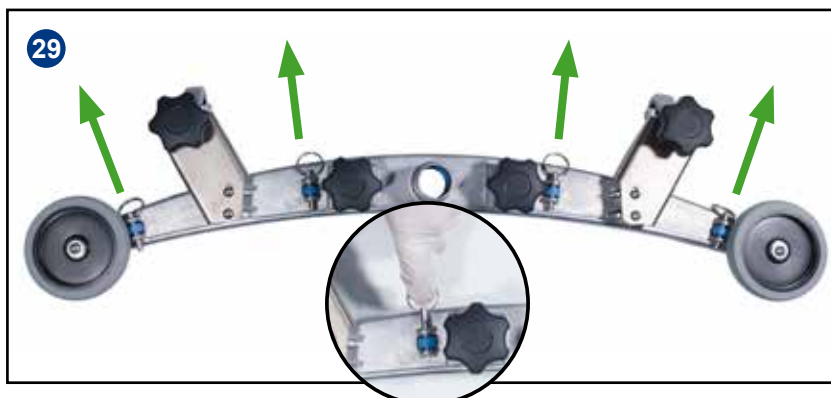

To clean the floor-tool, remove securing-pin and disconnect the lifting strap and remove the floor-tool securing pin pull-free the floor-tool from the rear of the machine. Rinse the floor-tool assembly with clean water and refit.



Periodically the floor-tool blades should be examined and checked for wear and damage.

The blade removal is easy. Simply start by removing the four retaining pins (see Fig.29), turn the floor-tool over and separate the blade carrier from the body (see Fig.30). Peel away the blades from their locating lugs (see Fig.31) and examine or renew as required. Replacement is a reversal of the removal process.

Floor-tool overview

1. Floor-tool main body
2. Rear blade
3. Blade carrier
4. Front blade (slotted)
5. Retaining pins x 4

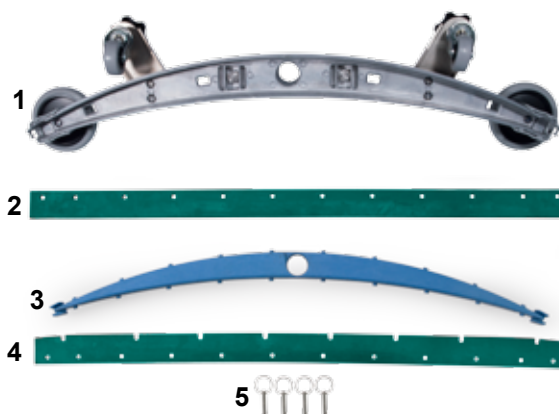

Note: The blades are designed to be reversible, thus extending their useful working life.

Off-Aisle Cleaning Kit (Optional Extra Accessory)



**In the event of a breakdown contact your Numatic dealer or the
Numatic Technical helpline +44 (0)1460 269268
(See back page for company addresses or dealers stamp)**

TT4045

TT 4045							
Brush Motor	Vac Motor	Brush Sizes	Pad Sizes	Net Weight	Gross Weight	Protection Class	Power
1500 W	1200 W	450 mm	400 mm	67 Kg	107 Kg	IPX4	230/120/100V - 50/60Hz
Fluid Flow	Speed	Capacity	Cleaning Range	Cleaning Speed	Hand Arm Vibration	Noise	Size
0-2L/Min	150rpm @ 50Hz 180rpm @ 60Hz	40 L	42 m	0-4 kph	1.4 m/s ²	76 ± 3 dB(A)	Width - 470mm Length - 890mm Height - 1100mm

TT 4055

TT 4055							
Brush Motor	Vac Motor	Brush Sizes	Pad Sizes	Net Weight	Gross Weight	Protection Class	Power
1500 W	1200 W	550 mm	500 mm	68 Kg	108 Kg	IPX4	230/120/100V - 50/60Hz
Fluid Flow	Speed	Capacity	Cleaning Range	Cleaning Speed	Hand Arm Vibration	Noise	Size
0-2L/Min	150rpm @ 50Hz 180rpm @ 60Hz	40 L	42 m	0-4 kph	1.4 m/s ²	76 ± 3 dB(A)	Width - 560mm Length - 935mm Height - 1100mm

Trouble- Shooting

PROBLEM	CAUSE	SOLUTION
Poor water pick-up	Waste-water tank full Clogged / blocked vacuum hose Loose hose connections Debris basket filter clogged / blocked Separator filter clogged / blocked Poor separator seal Damaged separator seal Damaged / split vacuum hose Damaged floor-tool blades	Empty waste-water tank (page 12) Remove and clean Push tight connections Remove and clean (page 12) Remove and clean (Page 12) Clean and refit (page 12) Renew (contact service dept) Renew (contact service dept) Renew (contact service dept)
No brush / scrub function	No brushes fitted Brush deck raised	Check and fit (page 7) Lower brush deck (page 7)
Little or no water flow	Clean-water tank empty Clean-water tank filter blocked / clogged Brush deck raised	Fill clean-water tank (page 8) Remove and clean (12) Lower brush deck (page 7)

Spare Parts & Accessories

237654	Top Tank - Blue	606203	450MM POLYSCRUB BRUSH
577839	Separator	606204	450MM NYLOSCRUB BRUSH
206953	DETENT PIN	606306	450MM LONGLIFE BRUSH
213058	Vac Hose	606028	550MM POLYSCRUB BRUSH
280019	Floor Tool Hose	606550	550MM NYLOSCRUB BRUSH
280018	Dump Hose - Top Tank	606551	550MM LONGLIFE BRUSH
213025	Dump Hose - Bottom Tank	606401	400mm PADLOC DRIVE BOARD
208960	Filler Hose - Bottom Tank	900526	500mm NULOC2 DRIVE BOARD
237718	Hose Guide	900521	650 Semi Parabolic Squeegee (4045)
206111	Dump / Filler Closure - Bottom Tank	900522	750 Semi Parabolic Squeegee (4055)
237268	Filler Cap Lid	900518	650 Floor Tool Blades - Green PU
207128	Filler Cap Filter	900519	750 Floor Tool Blades - Green PU
206265	Barrel Filter	236012	MAINS CABLE - UK
207000	Basket Filter	236132	MAINS CABLE - EURO
208888	Clean Water Filter	236020	MAINS CABLE - SWITZERLAND
208827	Clean Water Filter Body	236024	MAINS CABLE - SOUTH AFRICA
208890	Clean Water Filter Clear Bowl	236028	MAINS CABLE - USA
208830	Clean Water Filter Gasket	236118	MAINS CABLE - INDUSTRIAL 16 AMP
208889	Clean Water Filter Mesh	206813	SWITCH KEY

TT 4045, TT 4055 - Schematic Diagrams

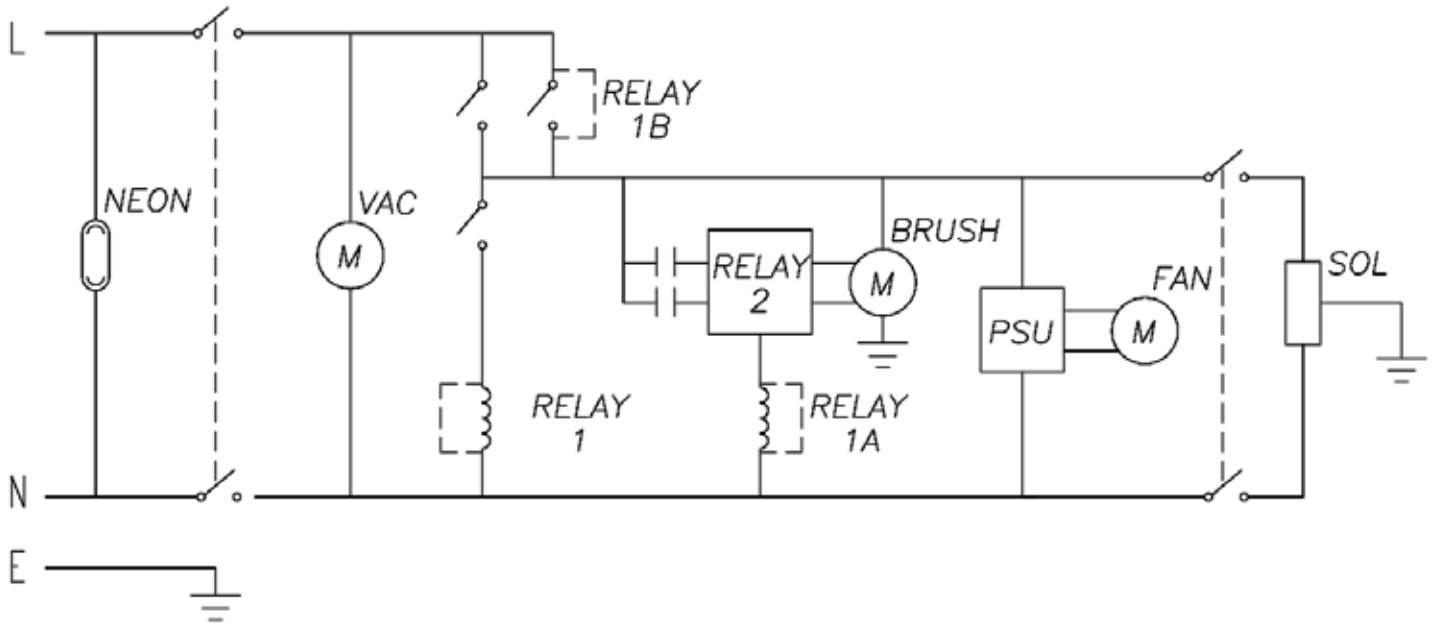

Notes

Notes

A series of horizontal dotted lines for writing notes.



**EU DECLARATION
OF
CONFORMITY**

We hereby declare under our sole responsibility that the following equipment fulfils all the relevant provisions of the following EU Directives:

Machinery Directive 2006/42/EC

EMC Directive 2014/30/EC

RoHS Directive 2011/65/EU

Machine Description:
Type: TT, ET series

Scrubber Dryer

Manufactured by:

Numatic International Limited

Relevant standards upon which conformity is declared include:

IEC 60335-1:2010

IEC 60335-2-72:2002 +A1

IEC 62233:2005

EN 55014-1:2006

EN 55014-2:1997+A1

EN 61000-3-2:2006

EN 61000-3-3:1995+A1+A2

A technical construction file for this equipment is retained at the manufacturer's address under the authorisation of the following signatory:

Name: Allyn Boyes

Position: Technical Manager

Signed:

Date: 20/04/2016



Numatic International Limited,
Chard, Somerset.
TA20 2GB
www.numatic.co.uk

GB

Numatic International Warranty

Numatic International Limited warrant to the original purchaser that its products are free of defects in both material or workmanship for the period shown below:-

Homecare and Cleancare Vacuum cleaners.....	2 Years
Rotary Floor Machines.....	2 Years
Twintec Auto Scrubber Dryer.....	1 Year
Vario Ride-On Scrubber Dryer.....	1 Year / 1500 hours
Mopping, Compacts, Combi and Servocare Products.....	1 Year
Individual Accessories and Spare Parts.....	6 Months

Note: This warranty expressly excludes consumable parts such as carbon brushes, floor brushes, mops, batteries etc, that are considered replaceable from time to time during the normal working life of the machine.

- A. The warranty period commences from the date the goods are purchased.
- B. All warranty claims must be processed through the Dealer from whom the equipment was purchased. The Dealer will co-operate with the purchaser throughout the warranty claims procedure and will arrange any necessary repairs using genuine Numatic parts.
- C. If the original Dealer is no longer able to fulfil his obligations please contact Numatic International Limited with full details of the claim and proof of purchase so that this may be processed without delay.
- D. Any warranty claim can only relate to the specific part that is proven to be at fault and for which a replacement will be supplied but cannot be extended to constitute a claim against the complete machine.
- E. Numatic International will supply the Dealer with any warranty parts required, subject to the claim being validated, after return of the faulty items in accordance with Numatic International Limited's General Conditions of Sale.
- F. Claims will not be accepted if they are the result of fair wear and tear, misuse or abuse of any kind.
- G. No replacement will be given unless the appropriate evidence of the validity of the claim has been provided to the satisfaction of Numatic International Limited.
- H. Numatic International Limited reserve the right to charge for any unnecessary work carried out as a result of an invalid claim.
- I. No variation to this warranty may be made or implied by any member of Numatic International Limited or its Dealers unless such variation is in writing and authorised by the Company



Numatic International Limited. Chard, Somerset, TA20 2GB

Telephone: 01460 68600 Fax: 01460 68458

© Numatic International Limited

This machine has been packed
with the following items:

Brush

Floor-tool

Hose Hook

38 mm / 32 mm Adaptor

Signed

TT 4045 / TT 4055



Distributed by



Numatic International Limited

Chard, Somerset

TA20 2GB ENGLAND.

Telephone 01460 68600 Fax: 01460 68458

www.numatic.co.uk

Subject to change without prior notice.

244466 06/16 (A08)